

NO	QTY	PART NO	DESCRIPTION	STD SEAL KIT
1	2	21500318	SCREW, SET, CUP PT, M5 X .8 X 10	
2	2	23050034	RING, RTNG, EXT, 0.312	X
3	4	23050035	RING, RTNG, EXT, 0.354	X
4	1	23050051	RETAINING RING, SPIRAL, INTL	X
5	1	29740200	SENSOR, ULTRASONIC, M12, 1m	
6	2	39051088	O-RING, (8mm X 3)	X
7	1	39051150	O-RING, (24mm X 2)	X
8	1	39052060	SEAL, ROD, RSD, 15, 85A, AU	X
9	1	39053041	SEAL, WIPER, SNAP IN, WED, 15, 94A, AU	X
10	1	39056032	SEAL, CAP, PISTON, 18, 94A, AU	X
11	1	43000040	O-RING, DIN3869, M18	
12	2	43061122	PLUG, SOCH, METRIC, M8	
13	2	43068004	PLUG, SOCH, G1/8	
14	2	81600147	LINK, LC, 7MPa, 40B	
15	2	81600152	PIN, LINK, LC, 7MPa, 40B	
16	1	81600157	PIN, PLUNGER, LC, 7MPa, 40B	
17	1	81600252	PLUNGER, LC, TL360, DA, 1400/6.22kN	
18	1	81600330	CAP, LC, TL360, 1400/6.22kN, US	
N/A	N/A	60160502	KIT, SEAL, ASSY, LC, TL360, DA, 6.22kN	NOTED

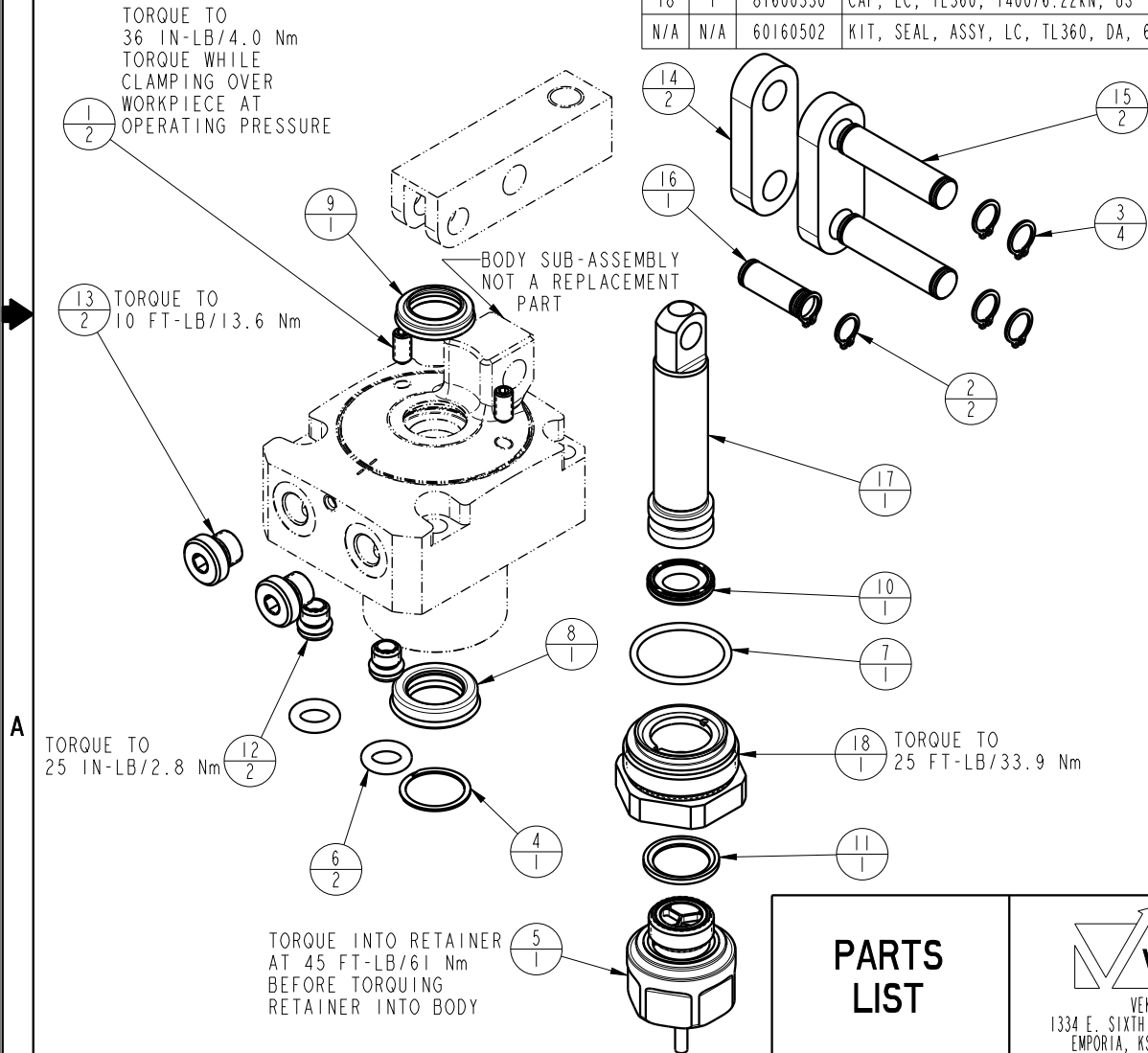

PARTS LIST	
	VEKTEK, INC. 1334 E. SIXTH AVE. P.O. BOX 625 EMPORIA, KS. 66801 U.S.A.
ASSEMBLIES AFFECTED 41621800US	PARTS LIST, ASSY, LC, TL360, DA, 6.22kN, US
SIZE A	MPL1636
	REV A

A	5660	RELEASE	ALS	3/24/25
REV	IN ACCORDANCE WITH ECN	EFFECTIVE DATE	REVISED BY	DATE
DRW BY:	ALS	DRAWING STATUS: Released PRODUCTION APPROVED FOR RELEASED STATUS ONLY		
DATE:	3/20/25			